

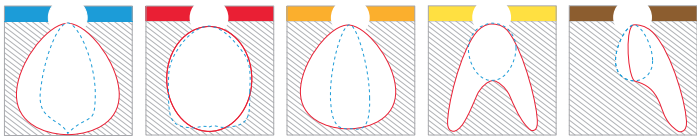

## COULEURS



La magenta effectue un équilibrage des phases automatique. Aucun recâblage n'est nécessaire. Les 3 phases doivent être alimentées en début de ligne.



Large (90 degrés) XL (92°X 40°) Medium (60 degrés) Double asymétrique (DASYM) Simple asymétrique (ASYM)

Flux lumineux	Lm/m	P/lum 1.75	P/lum 3.5	P w/m
HP830	2972Lm/m	5202lm	10404Lm	21W
HP840	3118lm/m	5457lm	10914Lm	21W
THP830	4896Lm/m	8568Lm	17136Lm	30W
THP840	4896Lm/m	8988Lm	17976Lm	30W
THP850	5136Lm/m	8988Lm	17976Lm	30W
TTHP830	6819Lm/m		23868Lm	43W
TTHP840	7354Lm/m	11682Lm	25740Lm	43W
TTHP850	7354Lm/m	11682Lm	25740Lm	43W

OPTION MAGENTA

Flux lumineux	longueur	Lumen	P système
TTHP830	3m50	15001Lm	94W
TTHP840	3m50	16178Lm	94W
TTHP850	3m50	16178Lm	94W

### NOTE:

Les platines LED sont installées sur le rail de manière à effectuer leur remplacement sans démonter le système complet



IP 20



230V  
50Hz

850°

IK10

## La perfection lumière

50 solutions lumière

Eblouissement minimisé

## Un investissement long terme

LEDs haut rendement

Température de jonction minimisée

pour 50 000h L70B20

## Une maintenance optimisée

Montage facile par grenouillère

Driver électronique intégré

Auto équilibrage des phases



SUSPENDU



TRACK



Alim  
driver intégré



module 1750mm: 3.6kg  
module 3500mm: 7.2kg

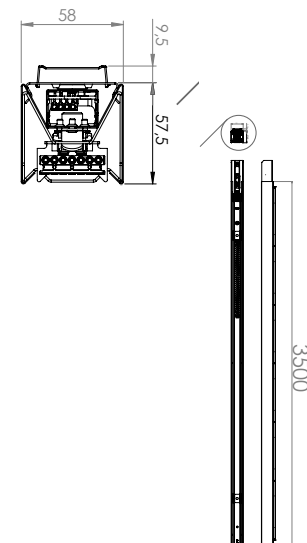

## Option :



Dali touch dim



LIGHT IN SHOP