

DREAM AIR DMX RGBCW

Éclairagiste/SCENO+



COULEURS



SOURCE RGBCW - 5 CANAUX DMX



Les angles des faisceaux sont représentés par des couleurs sur le plan et des gommettes sur les spots

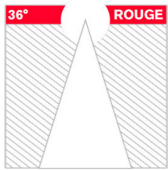

Luminaires qui ne sont pas conçus pour être recouverts avec un matériau isolant thermique.

CANAL	P lum	P syst	Efficacité lm/W
Canaux blancs (Tunable White)			
W – Warm White 2700K (IRC 90)	1854 lm	25 W	74 lm/W
C – Cool White 6000K (IRC 90)	2460 lm	25 W	98 lm/W
C+W mix 4000K typique	~ 4314 lm	50 W	86 lm/W
Canaux couleur (DMX)			
R – Rouge 620-630 nm	622 lm	12 W	52 lm/W
G – Vert 520-530 nm	980 lm	12 W	82 lm/W
B – Bleu 450-460 nm	215 lm	12 W	18 lm/W



La perfection lumière en couleur

- 1 puce RGBCW 5 canaux DMX
- Tunable White 2700K → 6000K (IRC 90)
- Couleurs saturées R / G / B
- Faisceau 36° optique HP aluminium
- Éblouissement minimisé

Un investissement long terme

- Aluminium de fonderie
- Tj minimisée pour 50 000 h L70B20 (à puissance nominale par canal)
- Puce Evercore NCW2320B-100W-LSH

Une maintenance optimisée

- Puce et driver DMX 100% retrofittables
- Vitre anti-poussière



ENCASTRÉ

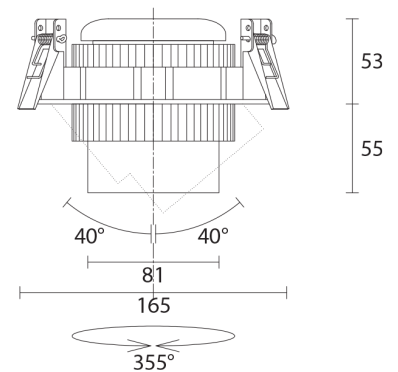

OPTIONS:



IP 20



230V
50Hz

850°

DMX 512
5 canaux

333 rue Marguerite Perey
77127 Lieusaint - France

contact@aristide.paris
www.aristide.paris

